

# Laing - the leader in instant hot water circulation technology

The Autocirc® is the most efficient system turning on only when the system needs to be replenished with hot water:

- saves energy, money, water and pays for itself in a short period of time
- is silent during operation
- has a built-in 24-hour timer which allows the selection of system operating periods to suit family usage
- has a built-in fixed thermostat or an optional, adjustable thermostat
- requires only one pump and one installation for all fixtures on the hot water plumbing line
- does not require a return line
- comes complete with a 6 ft. long power cord
- requires only 33 Watts of power
- saves the average family of four up to 17,000 gallons of water annually

## Saves money and pays for itself

Annual dollar savings using Laing Autocirc® System with gas or electrical water heater

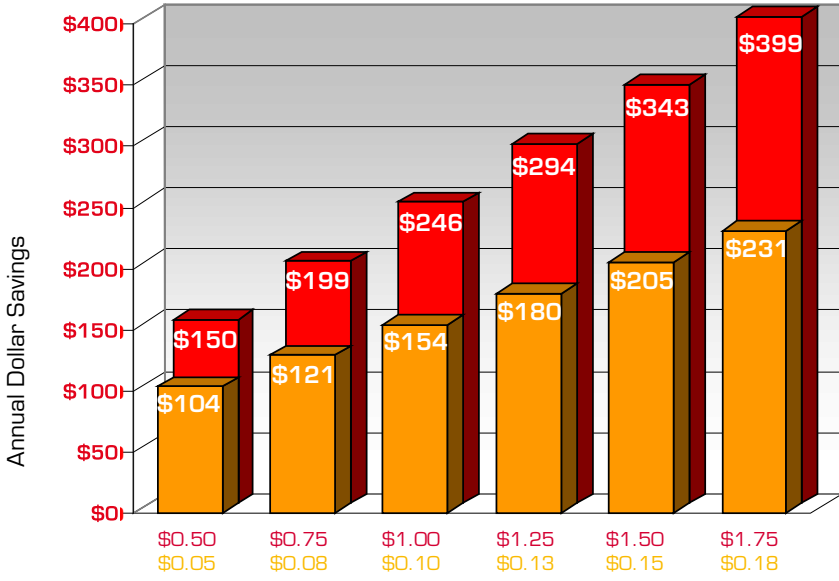

Calculations based on: Water cost= \$2.02/100ft³, Sewer surcharge = \$ 1.35/100ft³. Notes: Use of insulated copper supply line on Autocirc system would result in additional savings. Actual savings may differ from household to household depending on a variety of factors incl. water use habits, length of hot water supply line, number of home occupants, etc. Above summary based study and analysis prepared by Edward Saltzberg and Associates, Consulting Mechanical Engineers. Copies of this detailed analysis are available on request from Laing Thermotech, Inc.



Autocirc® is a complete retrofit solution for all homes and for light commercial applications. **It is the most efficient system, turning on only when the system needs to be replenished with hot water.** It does not require a return line and is suitable for installation in any existing home or building where hot and cold water pressure are evenly distributed. No additional piping is required in the installation.

Technical Datas	
Motor Design	Shaftless spherical motor
Horsepower	1/150
Input Watts / Amps	33 Watts
Max. fluid Temp. F / C	230°F / 110°C
Max. line pressure	150 PSI
Noise Level	15 dB
Compatible fluids	Domestic water, heating water, water/Glycolmixtures* . Other medias on request.

\*Please check pump performance for mixtures of 20% or more glycol.

Produced under one or more of the following patents:  
 5,941,275 / 5,944,221 / 5,983,922 / 6,026,844 /  
 6,059,965 / 6,149,407 , 5,072,717 / 6,227,235



Distributed by:

BR-25 (01/2008)



Laing Thermotech, Inc. · 830 Bay Blvd., Suite 101 · Chula Vista · CA 91911  
 Phone: (619) 575 - 7466 · Fax (619) 575 - 2739  
 E-Mail: customerservice@lainginc.com · Internet: www.autocirc.com

# Instant hot water at every faucet

Retrofit instant hot water system for every application

- **Saves Water**
- **Saves Money**
- **Saves Time**



# How Autocirc® works



The Autocirc® is the most efficient system, turning on only when the system needs to be replenished with hot water. The Pump is installed under the sink farthest from the water heater where hot water takes the longest to arrive. No recirculation line is required.

A built-in temperature sensor automatically turns the pump on when water temperature in the hot water line cools down to 85°F. Water is then pumped from the hot to cold line. Hot water will also be instantly available at all other faucets located on the hot water supply line between the water heater and the faucet where the Autocirc® is installed.

The Autocirc® Pump turns off automatically when water temperature reaches 95°F, ensuring instant availability of shower warm water with maximum temperature hot water only seconds behind. When the pump is off, a built-in auto closure device prevents any other hot-to-cold line or cold-to-hot line mix.

# Typical Installation Scheme

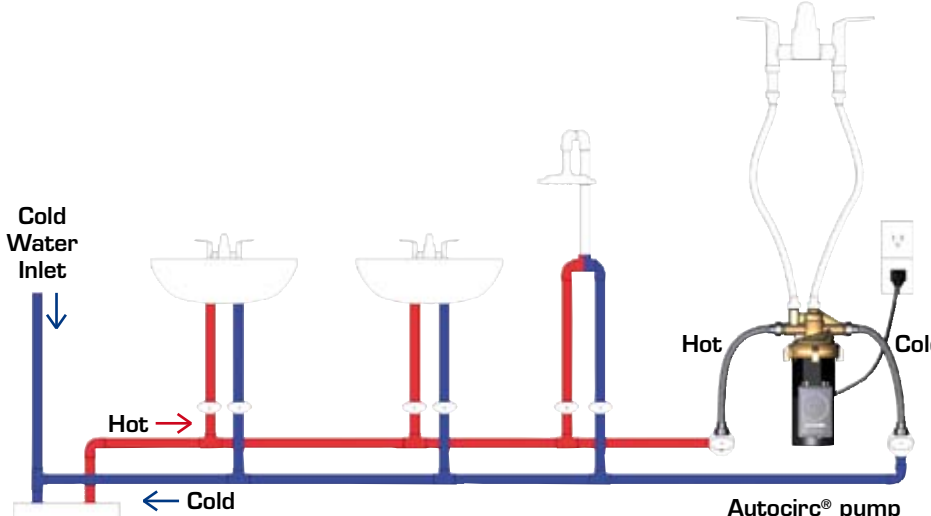

Note: At the sink under which the Autocirc pump is installed some "warmish" water will appear in the cold water line due to the transfer of water from the hot side to cold side. This warmish water will, however, disappear in a short time once the cold faucet is opened.

# Design

The Autocirc® has a spherical motor. The only moving part of the pump is a spherical rotor/impeller unit which is suspended on a wear resistant ceramic ball.

Laing pumps are completely shaft-less. The patented, Laing design eliminates problem shafts, seals and cylindrical bearings found on conventional, mechanically sealed canned pumps. Simply the best - by design.

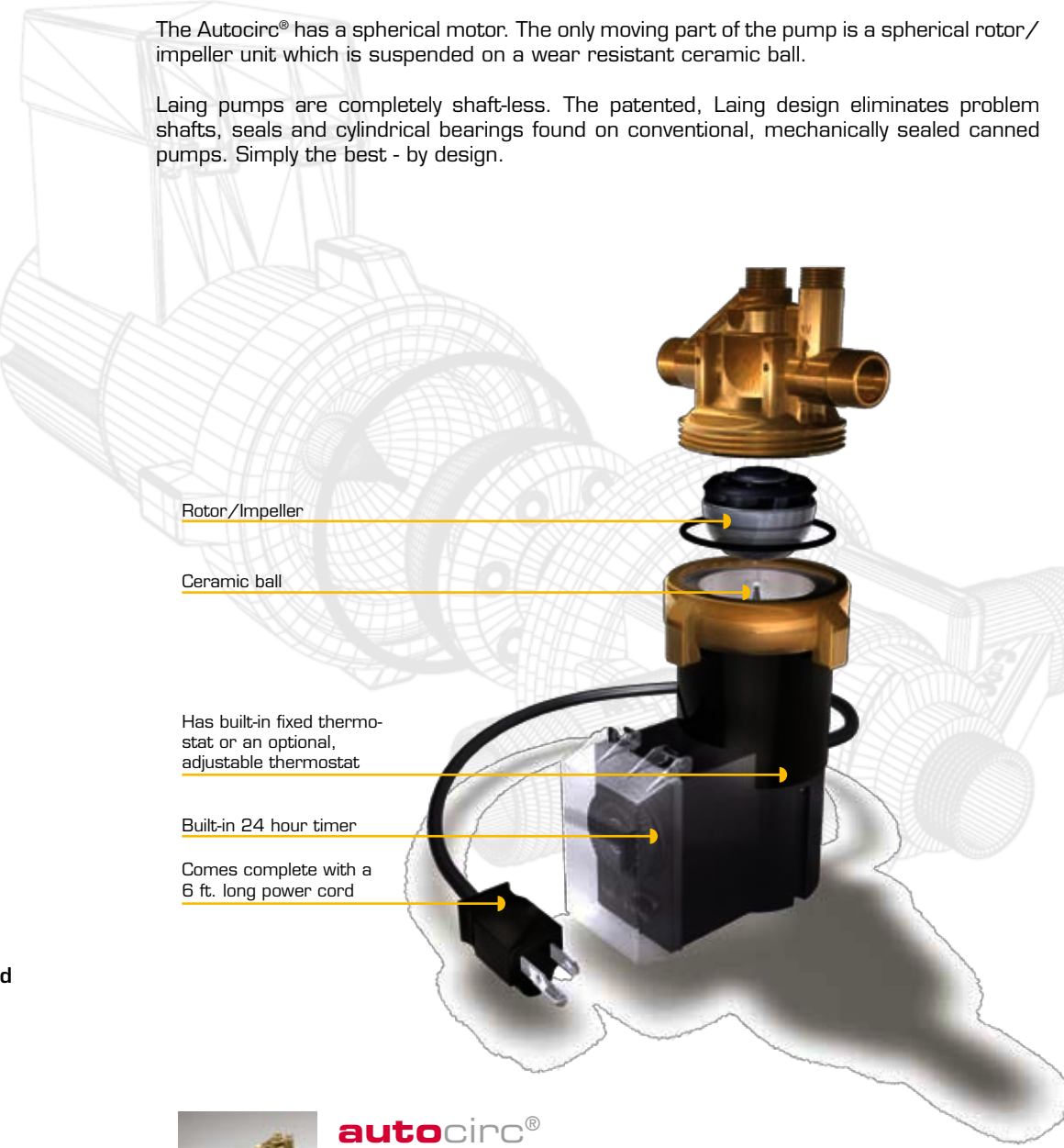

autocirc®

Model	Description
ACT-303-BTW	Pump with fixed thermostat
ACT-303-BTRW	Pump with adjustable ON thermostat

# Frequently Asked Questions and Answers

- Q. When should I consider installing an Autocirc® system?
  - A. In an existing home whenever you must wait 30 seconds or more for hot water to arrive at the faucet or at a shower farthest from your water heater.
- Q. Where should the system be installed?
  - A. Under the sink (plumbed between or to the side of the hot and cold water faucet inlet risers) where it takes hot water the longest time to arrive at the hot water faucet - usually the sink/faucet farthest from the water heater.
- Q. Is there a limitation on the size of the home or length of water supply line for the Autocirc® system to be effective?
  - A. No. The longer the line, the longer the pumps operating cycles. However, this is of no consequence to the system's effectiveness or system's life expectancy.
- Q. When I open the cold water faucet at the sink under which the Autocirc® system is installed, what prevents hot water from the hot water line from coming out of that faucet?
  - A. The pump housing has a patented, built-in auto closure device which prevents water from the hot water line coming through the cold water faucet and vice versa. The only exception is that when the cold water faucet is opened during one of the intervals when the pump is running, warm water will be directed from the hot water line through the cold water faucet. The warm water flow, however, will last only for a very short time and will end once the water temperature in the hot water line reaches 95°F thereby shutting off the pump.
- Q. What if I have a branched hot water piping system where one hot water supply line goes to one part of the home and another line goes to another part of the home?
  - A. Two Autocirc® systems would have to be installed, one under the farthest sink on each line.
- Q. Since water from the hot water line is being pumped into the cold water line, will there be any prolonged period of warm water coming out of the cold water line?
  - A. No. Once the cold water faucet is opened any "warmish" water in the cold water line takes only a very short time to dissipate before cold water arrives.
- Q. What is the temperature of the hot water at the hot water faucet when I first turn it on in the morning?
  - A. If the pump timer is set to allow the pump to go on before you turn on the faucet the temperature will be between 85°F and 95°F, which is basically shower warm water. However, full temperature hot water will arrive only seconds later.
- Q. Will the other faucets in my home have hot water instantly available?
  - A. With the Autocirc® system installed under the sink farthest from the water heater, all the hot water faucets directly on the main hot water supply line between the water heater and that farthest faucet will have instant hot water available. For those faucets located on branch lines off the main hot water supply line, availability of hot water will take slightly longer to arrive than for those faucets located on or just off the main water line.
- Q. My shower is a few feet downstream from the sink under which the Autocirc® system is installed. Will hot water be available instantly also at the shower?
  - A. Not Quite. Hot water will arrive once the few feet of cooled down water that is in the hot water line between the sink and shower flushes through the shower head - literally in seconds as compared to your previous wait.
- Q. Does the pump cycle on and off frequently during the day?
  - A. Yes. The pump will cycle on and off from 1-2 times per hour during the operating time period you set on the pump timer on/off operation. No matter how many cycles, it is in no way harmful to the pump or to its expected operating life, an additional advantage of the pump's spherical motor design.
- Q. Will I hear the pump during operation?
  - A. No. The pump system is virtually noiseless.
- Q. How much does the system cost to operate?
  - A. Actually an Autocirc® installation saves money - see the cost savings chart.